

How to install Composite Repetitions

Note: All pictures can be enlarged for better clarification.

Required Tools

Revision 6, 12/2008

Shop Tools

Bead blasting unit (Optional)
Table Saw (if necessary)



Fig. 1
Bead blaster

Hand Tools

Phillips or Slot screwdriver as required
Small 6" square
Right angle die grinder, available from, WNG part # 06-0265
Quick-change disc holder for 2" discs, WNG part # 06-0266



Fig. 2
Right angle die grinder
W quick-change disc
holder for 2" discs

Supplies

Sand paper for rails (Emery/sand paper, 100 grit)
Sand paper to sand hammer rail (150 grit)
Travel paper – several size/thickness
WNG Glue, WNG part # 06-5617

1" Masking tape
Quick change sanding disks - 80 grit, WNG part # 06-0267

Supplies (cont.)
Dust mask
Safety glasses
Ear protection

Procedure

1. Select the correct repetition.
 - a. WNG has pre-configured a number of repetitions for simple screw on replacement. Choose the correct replacement.

NOTE: We highly recommend the WNG Sample kit (part # 06-5231) that includes all the Composite action parts made by WNG Company. The Sample kit is a great aid in ordering the correct parts and the purchase price is refunded upon purchase of product.

- b. For pianos that do not match any of the pre-configured repetitions WNG has provided, you will need to take the following steps to define a custom repetition.
 - i. Make sure that the repetition you wish to replace measures 99mm +/- 1mm between the repetition flange center and the jack center. (See Fig. 3, lower part)
 1. If the repetition does not meet the 99mm standard you can still engineer the WNG repetition into your piano however, it will not be a simple "screw the repetition onto the rail" situation.
 - ii. Does the repetition need an integrated rest cushion? (See Fig. 3)

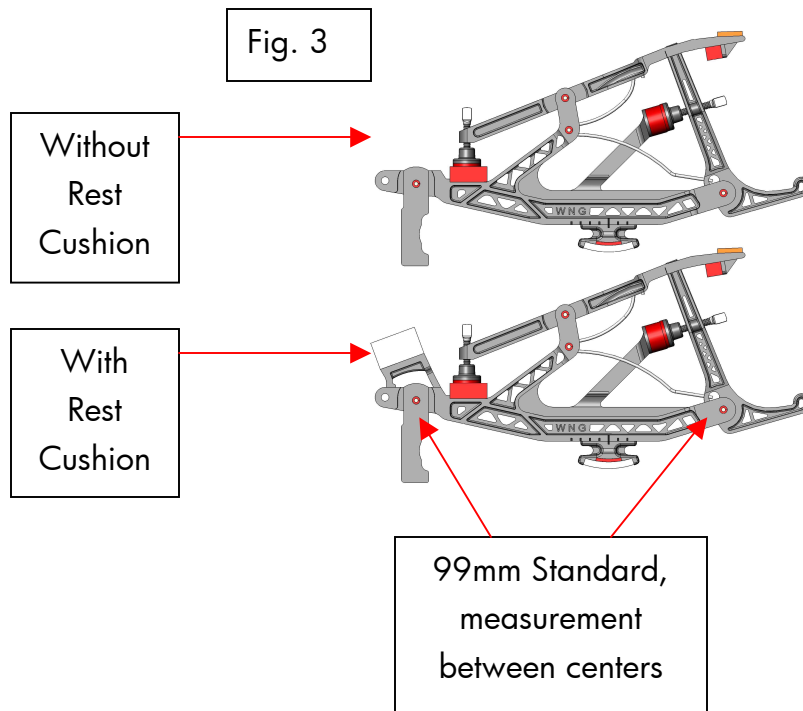

iii. Pick the correct flange to match the shape of the rails in your piano.

1. If none of the flanges available are an exact match, you still might be able to pick a flange that would attach well enough to work.

2. However, if none of the flanges work on your rails well enough to function, you will need to contact WNG Company for further options.

iv. Pick the proper jack to work with the regulation rails in your piano.
(See Fig. 4)

1. WNG has a high angle jack and a low angle jack.

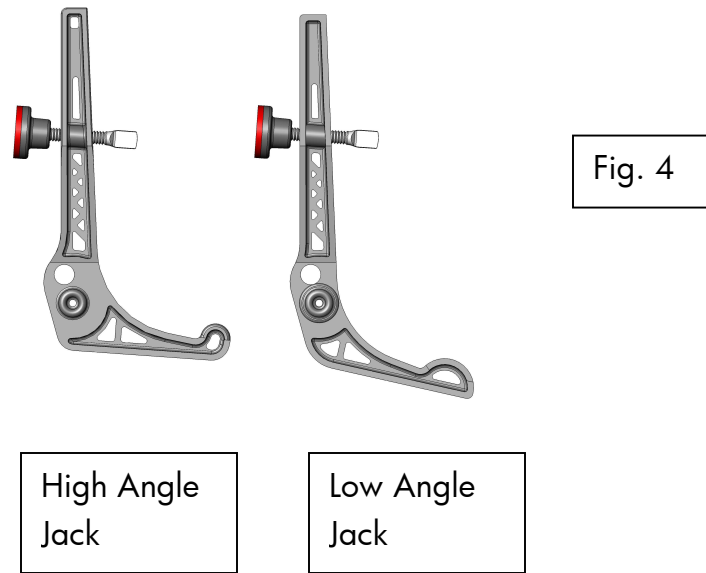

- a. One or the other of these jacks will likely work in your action.
 - b. If neither jack will work in this action frame, you will need to alter your regulation rail so it will allow the use of one of these jacks. Possibly a button or screw change is all that is necessary.
- v. Select the correct heel size and location to match the height of the repetitions you are replacing.

**NOTE: You can view all WNG parts at:
WWW.wesselnickelgross.com**

NOTE: You should note that often it is possible to improve the geometry and leverage of the action by careful modification of the height and location of the heel. If you go this route, you will need to re-locate the capstan.

At that point, a sensible choice would be the WNG hard-anodized aluminum capstan (Set of 90 part # 06-5303 available from WNG) that greatly reduces the weight of the capstan in a very important place.

2. Remove the old repetitions.
 - a. Remove old repetitions from the repetition rail.
3. Clean the screws as needed.
 - a. Many rebuilders will bead blast or otherwise remove any and all corrosion from the action screws while off the action so the job will look “like new” when completed.

Note: For actions with wooden rails, you may need a minor clearance modification on the repetition rail. Because of the shape of the WNG repetition you will need to create a clearance cut on the top front corner of the repetition rail. (See Fig. 5)



Fig. 5
Repetition hits unmodified repetition rail

4. Modify the repetition rail as needed.
 - a. Place sample repetitions on the rails at notes 1 and 88.
 - b. Mark the end of the rail so that when the repetition is regulated, there is 1/8” (3mm) clearance between the repetition and the action rail. (See Fig. 6)

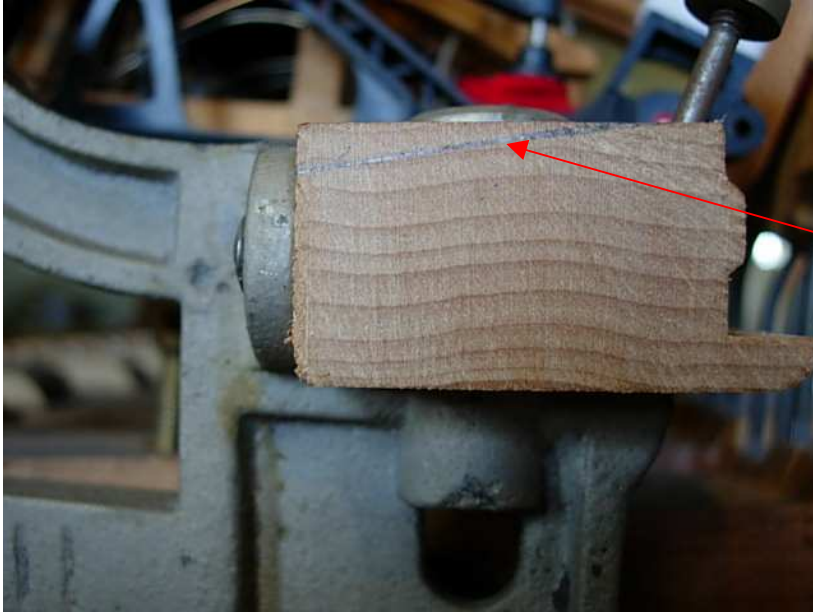

Fig. 6
Mark rail for 1/8" (3mm)
clearance to bottom of
repetition

- c. Remove the rail from the action brackets.
 - i. Make sure that you have set the spread and shimmed the rail. (See Fig. 7)
 - ii. This will allow you to correctly position the repetition rail when you reinstall it on the action brackets.



Fig. 7
Measure Spread

- d. Cut the rail on a table saw.
 - i. Set up the saw for an angle cut to match your marks.
 - ii. Cut the rail.

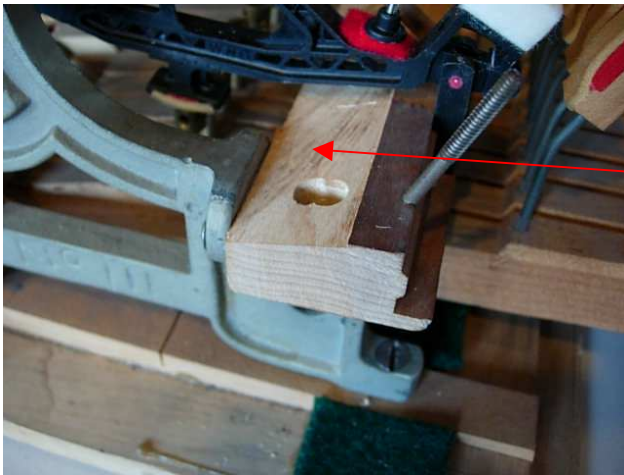

Fig. 8
Cut angle on
repetition rail

- e. If the cut you made, on the table saw, makes an angled surface at the mounting screw locations, then you need to shim up these areas for the screws.
 - i. Cut a wedge at the same angle for the screws to pull against.
 - 1. The grain needs to run the same way that the grain runs in the repetition rail.
 - ii. Glue this wedge onto the rail at each screw location. Make sure that the height is the same as before. (See Fig. 9)

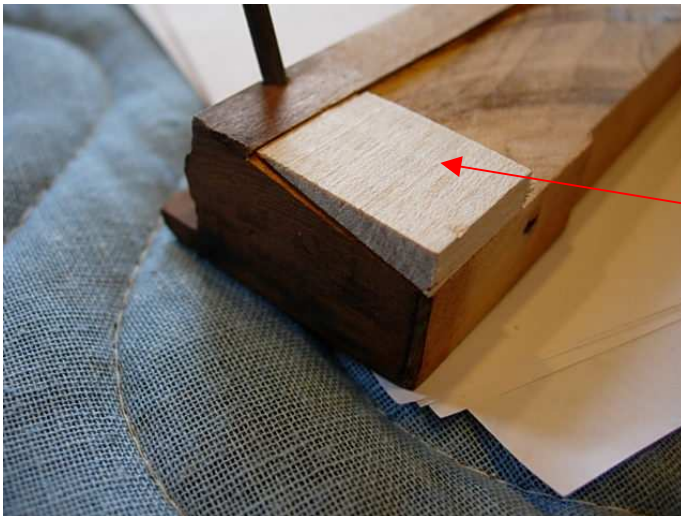

Fig. 9
Glue wedge on
angle cut to
provide square
surface for screw

- iii. Drill the hole thru the shim.
 - 1. Pick a drill size that matches the size of the screw hole in the rail.
 - 2. Clamp a scrap piece of wood over the rail to drill into. This will insure a clean hole without damaging the wedge.
 - 3. Place the repetition rail up side down and drill thru the wedge at each location.
- f. Re-install the repetition rail on the action brackets. (See Fig 8)

- i. Make sure that the spread has not changed. (See Fig. 7)
- ii. Make sure that the location of the rail side to side has not changed.



Fig. 10
Repetition rail re-
installed with
proper clearance

5. Clean the action frame as needed.
 - a. Many rebuilders will sand the action frame so that the job will look “like new” when completed.
 - b. Some will even apply a seal coat of a finish to the rails to enhance stability during humidity changes.
6. Check repetition center height against known specifications for the piano you are working on if you have them.

NOTE: Here is a simple gage that helps ease the measurement of the hammer and repetition center adjustment we call, The Top Action Height Gage. The wood dimensions are 2”x2”x 9”. Make sure the piece of wood is square about 9” long with the wire pointer at 3 ¼” from the end of the block. (See fig. 11)

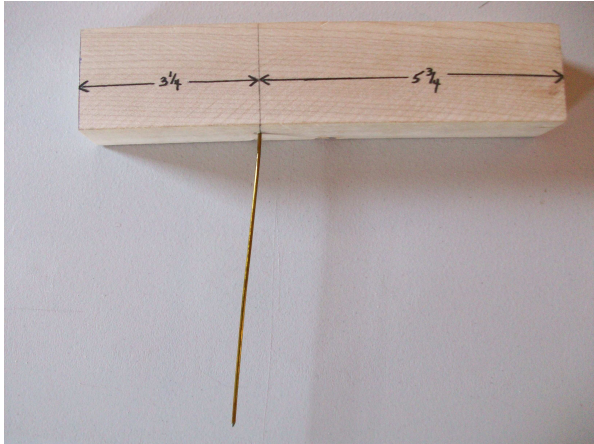

Fig. 11
Top Action
Height gage jig

- a. Many re-builders will re-set the action to the correct action center locations for both the shank and repetition center heights as well as spread. (See Fig. 13 and 14)
- b. Place the sample repetitions at the ends of sections to check center heights.
 - i. Set the top action height gage to the factory setting by bending the wire up or down. (See Fig. 12)

Place the gage at the center pin and modify as required. (See Fig. 13 and 14)

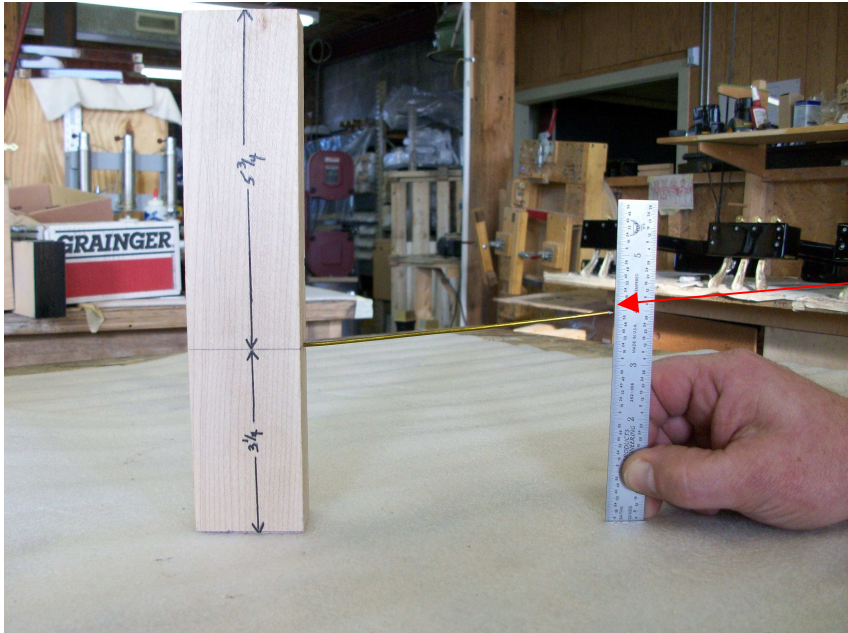

Fig. 12
Setting Height
Gage for centers

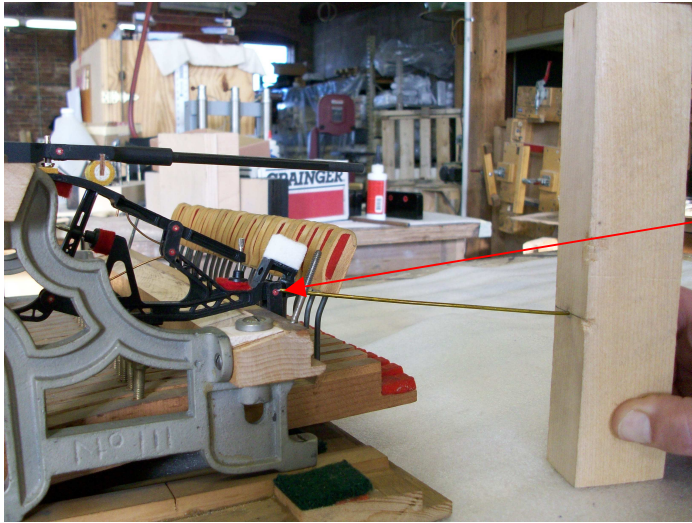

Fig. 13
Checking
Repetition Center
Height



Fig. 14
Checking
Hammer Center
Height

- 7. Install the new WNG repetitions on the rails. In a WNG Composite set of repetitions there are three types of springs in the Bass, Tenor and Treble. (See Fig. 15)
 - i. Repetitions are color coded on the bottom for the spring size. (See Fig. 15)
 - 1. Red for bass (30)
 - 2. White for tenor (30)
 - 3. Blue for treble (30)

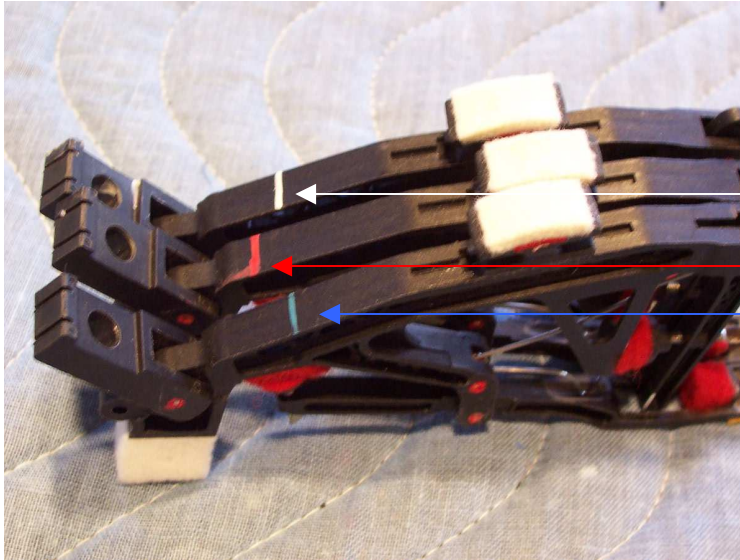

Fig. 15
Repetition Spring
color-coding

- b. Place each repetition on the rail and attach with a screw.
 - i. Since you will be traveling, only a light tightening the screw is required.
 1. Be careful with tightening, as it is easy to strip the screws in an action rail.
 - ii. Install all 88 repetitions in their appropriate locations.
- c. Square and space the repetitions to the front of the rail.
 - i. Use a square from the front of the rail to get the repetitions perpendicular to the shank rail.

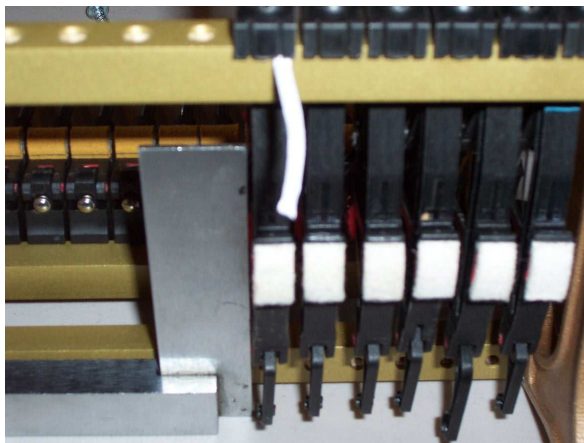

Fig. 16
Square and space
repetitions

- ii. Space so that there is approximately even spacing in each section.
- iii. These steps will help you solve any traveling problems.

8. Travel the repetitions.

- a. What is “traveling” and why do you need to travel a repetition? There are two traveling sessions with repetitions.
 - i. The first occurs right after the repetitions are installed on the rails.
 - 1. In the first traveling, the repetition is only squared to the rail. This will get the repetition in approximately the correct position for the second traveling operation, which occurs after the hammers are spaced to the strings. (See Fig. 16)
 - ii. The second traveling occurs after the top action is mounted on the keyboard and the hammers are spaced to the strings.
 - 1. Tilt the repetition so that the balancier is centered under the knuckle.
 - 2. Check the location of the capstan under the heel and the jack tender under the regulating button.
 - 3. Using a combination of tilt and travel paper, try to center the capstan under the heel, the jack under the regulating button while keeping the balancier centered under the knuckle. If any compromise is necessary, the Knuckle is the more important one.